

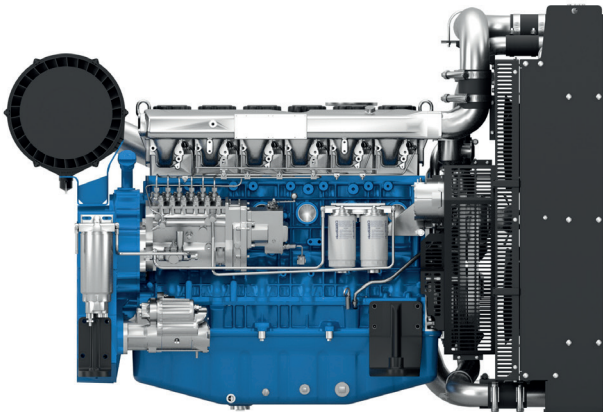

# 6M21

PowerKit ESP/PRP/COP Diesel Engine



Bore & Stroke (mm)	127 x 165
Displacement (L)	12.54
N° of Cylinders	6
Cylinders Arrangement	In line
Fuel System	Mechanical pump/ High Pressure Common Rail
Governor (Gov.)	Electronic/ ECU
Aspiration (Asp.)	Turbocharged & air-to-air cooled

### Customer benefits

Warranty terms - 2 yrs unlimited hours PRP, 4 yrs / 800 ESP  
 50°C Cooling package standard with low derating  
 Extended mean time between overhauls (MTBO)  
 Dual Speed Engine

ESP/PRP									
ESP/PRP/DCP Diesel Engine Models	Gross Engine Output		Typical Generator Output				RPM	Asp.	Gov.
	ESP	PRP	ESP		PRP				
	kWm		kWe	kVA	kWe	kVA			
6M21G400/5	385	350	320	400	300	375	1500	T/A-A	ELEC
6M21G440/5	405	368	352	440	320	400	1500	T/A-A	ELEC
6M21G500/5	450	409	400	500	360	450	1500	T/A-A	ECU
6M21G550/5	490	450	440	550	400	500	1500	T/A-A	ECU
6M21G330/6	385	350	330	413	300	375	1800	T/A-A	ELEC
6M21G2D0/S	402	366	344	430	312	390	1800	T/A-A	ELEC
6M21G390/6	448	407	390	488	350	438	1800	T/A-A	ELEC
6M21G400/6	460	418	400	500	360	455	1800	T/A-A	ECU
6M21G460/6	510	450	460	575	400	500	1800	T/A-A	ECU

\* Please note that models ending with S are switchable engines

COP									
COP Diesel Engine Models	Gross Engine Output		Typical Generator Output				RPM	Asp.	Gov.
	COP	PRP	COP		PRP				
	kWm		kWe	kVA	kWe	kVA			
6M21G2D0/5	303	368	260	325	320	400	1500	T/A-A	ELEC
6M21G2D0/6	350	407	300	375	350.4	438	1800	T/A-A	ELEC

### Standard Equipment

Engine and block	Cast iron frame style body structure One-piece forged crankshaft Split-cap forged steel connecting rods Separate cast iron cylinder heads with 4 valves Replaceable dry cylinder liners Aluminum alloy pistons with oil cooling gallery
Cooling System	Radiator and hoses supplied separately Thermostatically-controlled system with belt driven coolant pump and pusher fan
Lubrication system	Flat bottom large capacity oil pan Spin-on full-flow lube oil filter
Fuel system	P type fuel injection pump and injector for higher inject pressure, for engines with electronic governor High pressure Common Rail injection system, for engines with ECU Duplex fine filter and water separation filter assembly with transparent cup for better efficiency
Air intake and exhaust system	Mid-position and below inlet turbocharger optimized for genset application Special rear mounted air filter with restriction indicator Exhaust manifold shield for heat isolating
Electrical System	24 Vdc electric starter motor and battery charging alternator LOP + HWT sensors
Flywheel and housing	SAE 1 flywheel housing and 14" flywheel

### Dimensions and dry weight (mm/kg)

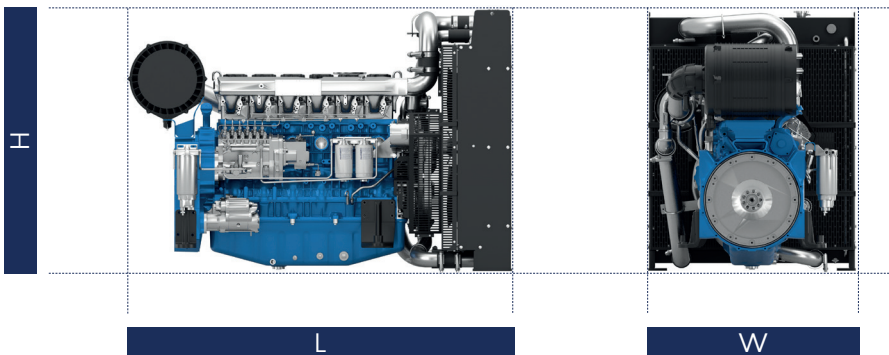

Diesel Engine	Speed RPM	Dimensions and dry weight including radiator			
		L	W	H	Weight
		mm	mm	mm	Kg
6M21G400/5	1500	2011	1096	1363	1150
6M21G440/5	1500	2011	1096	1363	1150
6M21G500/5	1500	2027	1105	1373	1160
6M21G550/5	1500	2032	1232	1490	1190
6M21G330/6	1800	2011	1096	1363	1150
6M21G390/6	1800	2011	1096	1363	1150
6M21G400/6	1800	2027	1105	1373	1160
6M21G460/6	1800	2032	1232	1490	1190
6M21G2D0/S	1500/1800	2011	1096	1363	1150

## Ratings definitions

### Emergency Standby Power (ESP)

Emergency Standby Power is the maximum power available for a varying load for the duration of a main power network failure. The average load factor over 24 hours of operation should not exceed 70% of the engine's ESP power rating. Typical operational hours of the engine is 200 hours per year, with a maximum usage of 500 hours per year. This includes an annual maximum of 25 hours per year at the ESP power rating. No overload capability is allowed. The engine is not to be used for sustained utility paralleling applications.

### Continuous Power (COP)

Continuous Power is the maximum power available for an unlimited period of use at a constant load factor. No overload capability is allowed.

### Prime Rated Power (PRP)

Prime Power is the maximum power available for unlimited hours of usage in a variable load application. The average load factor should not exceed 70% of the engine's PRP power rating during any 24 hour period. An overload capability of 10% is available, however, this is limited to 1 hour within every 12 hour period.

- 1) All ratings are based on operating conditions under ISO 8528-1, ISO 3046, DIN6271. Performance tolerance of  $\pm 5\%$ .
- 2) Test conditions: 100 kPa, 25°C air inlet temperature, relative humidity of 30%, with fuel density 0.84 kg/L.  
Derating may be required for conditions outside these; please contact the factory for details.

