

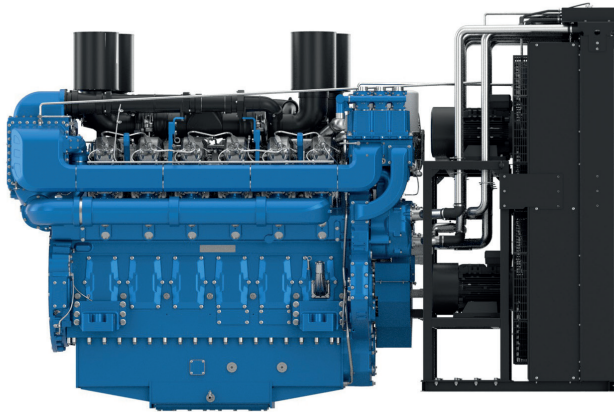

12M55

PowerKit ESP/PRP/DCP/COP Diesel Engine



Bore & Stroke (mm)	180 x 215
Displacement (L)	65.6 L
N° of Cylinders	12
Cylinders Arrangement	At Vee
Fuel System	High Pressure Common Rail
Governor (Gov.)	ECU
Aspiration (Asp.)	Turbocharged & air-to-water cooled

Customer benefits

Warranty terms – 2 yrs unlimited hrs, 4 yrs/800h ESP
 50°C Cooling package standard with low derating
 Extended mean time between overhauls (MTBO)

ESP/PRP/DCP Diesel Engine Models	Gross Engine Output			Typical Generator Output						RPM	Asp.	Gov.
	ESP	PRP	DCP	ESP		PRP		DCP				
	kWm			kWe	kVA	kWe	kVA	kWe	kVA			
12M55G2300/5	2020	1850	-	1840	2300	1680	2100	-	-	1500	T/A-W	ECU
12M55G2550/5 [^]	2210	1985	1985	2040	2550	1824	2280	1800	2250	1500	T/A-W	ECU
12M55G2750/5	2450	2200	2200	2200	2750	2000	2500	2000	2500	1500	T/A-W	ECU
12M55G3000/5 [^]	2700	2420	-	2400	3000	2200	2750	-	-	1500	T/A-W	ECU
12M55G2000/6	2230	2050	-	2000	2500	1852	2315	-	-	1800	T/A-W	ECU
12M55G2250/6	2460	2200	-	2250	2813	2045	2557	-	-	1800	T/A-W	ECU
12M55G2500/6 [^]	2725	2450	2450	2500	3125	2250	2813	2250	2813	1800	T/A-W	ECU

* [^] Primarily for ESP applications

COP Diesel Engine Models	Gross Engine Output		Typical Generator Output				RPM	Asp.	Gov.
	COP	PRP	COP		PRP				
	kWm		kWe	kVA	kWe	kVA			
12M55G2D0/5	1805	1985	1600	2000	1800	2250	1500	T/A-W	ECU
12M55G2D0/6	2015	2200	1800	2250	2000	2500	1800	T/A-W	ECU

Dimensions and dry weight (mm/kg)

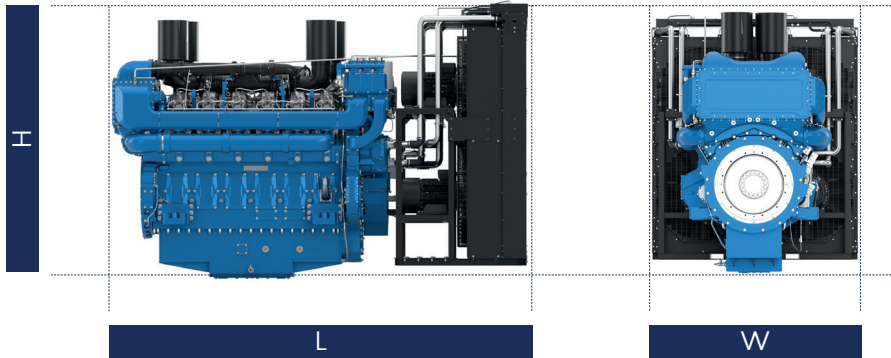

Diesel Engine	Speed RPM	Dimensions and dry weights including radiator							
		Without radiator				Electrical optional radiator			
		L	W	H	Weight	L	W	H	Weight
mm	mm	mm	Kg	mm	mm	mm	Kg		
12M55G2300/5	1500	2958	1544	2616	9550	4193	2241	2787	11500
12M55G2550/5	1500	2958	1544	2616	9550	4193	2241	2787	11500
12M55G2750/5	1500	2958	1544	2616	9550	4193	2241	2787	11500
12M55G2D0/5	1500	2958	1544	2616	9550	4193	2241	2799	11500
12M55G3000/5	1500	2958	1544	2616	9550	4193	2241	2787	11500
12M55G2000/6	1800	2958	1544	2616	9550	4193	2241	2787	11500
12M55G2250/6	1800	2958	1544	2616	9550	4193	2241	2787	11500
12M55G2500/6	1800	2958	1544	2616	9550	4193	2241	2787	11500
12M55G2D0/6	1800	2958	1544	2616	9550	4193	2241	2799	11500

Ratings definitions

Emergency Standby Power (ESP)

Emergency Standby Power is the maximum power available for a varying load for the duration of a main power network failure. The average load factor over 24 hours of operation should not exceed 70% of the engine's ESP power rating. Typical operational hours of the engine is 200 hours per year, with a maximum usage of 500 hours per year. This includes an annual maximum of 25 hours per year at the ESP power rating. No overload capability is allowed. The engine is not to be used for sustained utility paralleling applications.

Data Centre Power (DCP)

Data Centre Power is defined as being the maximum power which a generating set is capable of delivering while supplying a variable or continuous electrical load and during unlimited run hours. Depending on the sites to supply and the availability of reliable utility, the generating set manufacturer is responsible to define what power level he is able to supply to fulfil that requirement including hardware or software or maintenance plan adaptation.

Continuous Power (COP)

Continuous Power is the maximum power available for an unlimited period of use at a constant load factor. No overload capability is allowed.

Prime Rated Power (PRP)

Prime Power is the maximum power available for unlimited hours of usage in a variable load application. The average load factor should not exceed 70% of the engine's PRP power rating during any 24 hour period. An overload capability of 10% is available, however, this is limited to 1 hour within every 12 hour period.

- 1) All ratings are based on operating conditions under ISO 8528-1, ISO 3046, DIN6271. Performance tolerance of $\pm 5\%$.
- 2) Test conditions: 100 kPa, 25°C air inlet temperature, relative humidity of 30%, with fuel density 0.84 kg/L.
Derating may be required for conditions outside these; please contact the factory for details.

